

Model AJ1 FEN

BROADBAND COST EFFECTIVE DIPOLE

- Model A1JFEN – AJ1FE6 – AJ1FE7
- Band II dipole
- Broadband 87.5÷108 MHz
- 2 dBd gain
- Vertical polarization
- Omni directional pattern
- Hot-dip galvanized steel

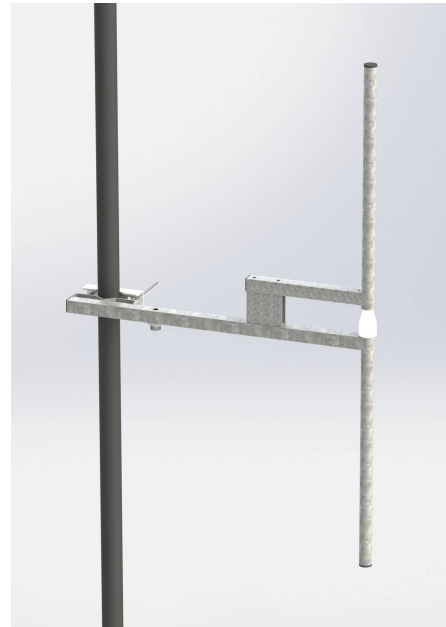

ELECTRICAL DATA	
Frequency range	87.5÷108 MHz
Impedance	50 Ohm
Connectors	N (AJ1FEN) – 7/16 female (AJ1FE6) – 7/8 EIA (AJ1FE7)
Max Power	800W (N) – 2KW (7/16" - 7/8" EIA)
VSWR	≤ 1.35:1 Average
Polarization	Vertical
Gain	2 dB (referred to half-wave dipole) at 98 MHz
Pattern	Omni directional ± 1.5 dB in free space Omni directional ± 3 dB with 100mm diameter pole
Lightning protection	All metal parts DC grounded

MECHANICAL DATA	
Dimensions	1400x900x50 mm
Weight	7 kg with hardware mounting
Wind surface	0.05m ²
Wind load	9.8 kg (wind speed at 160 km/h – without radome)
Max wind velocity	220 km/h.
Materials	External parts: Hot-dip galvanized steel Internal parts: brass Radome: fiberglass (optional)
Icing protection	Feed point radome (optional)
Radome (optional)	Color white
Mounting	With special pipe clamps 40÷110 mm diameter

RADIATION PATTERN (MID BAND)

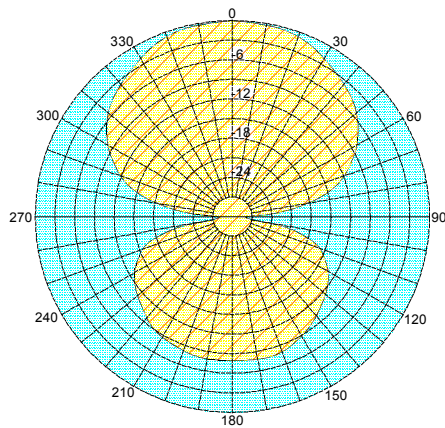

E-plane

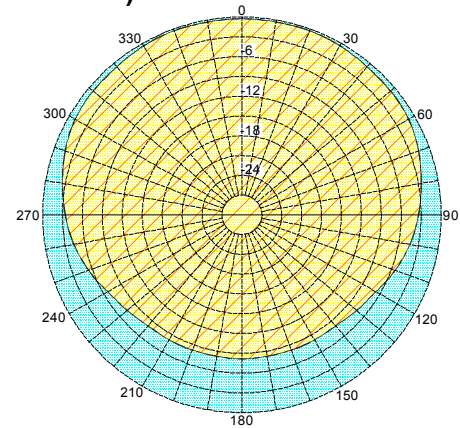

H-plane

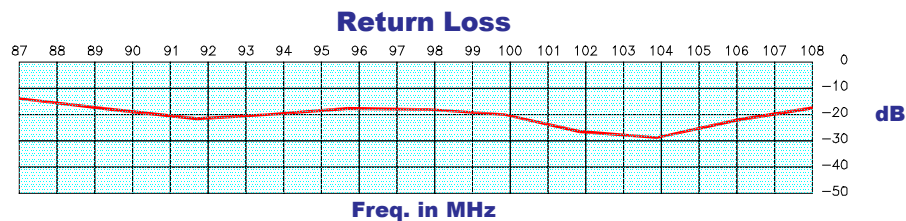

Broad Band Cost Effective Antenna Systems with the AJ1

Omni - directional pattern

ELECTRICAL DATA	
Frequency range	87.5÷108 MHz
Impedance	50 Ohm
Connector	EIA flange according to system power rating
VSWR	≤ 1.35:1 Max
Polarization	Vertical
Gain	According to requirement
Horizontal pattern	Any type according to the customer requirements
Vertical pattern	Null fill, beam tilt and special requirements on demand
Other facilities	The antenna system can be supplied in split feed with two equal half antennas. Each half can accept full power

MECHANICAL DATA	
Height of array	Subject to number of bays (refer to table)
Total net weight	Refer to table
Wind load	Refer to table
Pressurizable	Yes (on demand)
Radome colour	White (optional)
Mounting hardware	Hot dip galvanized steel clamps
Shipping	As required

TECHNICAL DATA						
Number of bays	Dipole per bay	Gain ¹		Weight ² kg	Antenna height L m	Wind load (v=160 km/h) kg
		dB	times			
1	1	2.0	1.6	7	1.4	9.8
2	1	5.0	3.2	14	4.0	19.6
4	1	8.0	6.3	28	9.2	39.2
6	1	9.8	9.5	42	14.4	58.8
8	1	11.0	12.7	56	19.6	78.4

¹ Referred to half wave dipole. Attenuation of connecting cables not taken into account.

² Without mounting hardware.

³ Systems comprise: antennas, cables and splitter – for more details look on catalog – different versions on demand

- Gain is provided for vertical polarisation.
- When antenna is pole mounted on the top of a tower the horizontally polarized radiation pattern is omni - directional.
- If the antenna is side mounted, the supporting structure will have a slight effect on the radiation pattern and VSWR.
- Vertical tower space, wind load and weight numbers given are typical. Actual values vary with the specific installation. Contact us for more details of your installation.
- Gain will be reduced if null fill, beam tilt or special wavelength spacing are provided.
- Antenna radiation aperture is the distance from the centre of the top bay to the centre of the bottom bay.
- A length of five ft(1.6mt) of pipe is required above the top bay and below the bottom bay to protect from pattern interference by other antennas.
- Antenna wind load is calculated for 100 Mph (160Km/h) per EIA-222-C standard.

